



FEATURES:

- PFD input frequency range: 10 MHz to 150 MHz
- Output frequency range: 50 MHz to 1.4 GHz
- Operating voltage range: 1.08 V to 1.32 V
- Operating junction temperature: -40° C to 125° C
- Area: 400 μm X 300 μm
- Pre-divider ratios: 1, 2, 4, 8
- Loop-divider Dy range: 2 to 32
- Built-in loop filter
- Power-down mode
- Built-in lock detection
- Built-in ring oscillator
- By-pass mode

APPLICATIONS:

- Clock multiplication, clock generation

TECHNOLOGY:

- CHRT 0.18 μm generic IB CMOS

STATUS:

- MPW in progress

JITTERS:

- Peak-to-peak period jitter:
- RMS period jitter:

Brief description

The Haokai_PLL_180CHRT_01, a 0.18 μm phase locked loop (PLL), provides a clock generation and multiplication circuit that generates a stable, high-speed clock from a clock signal with medium high input frequency (10 MHz to 150 MHz). A differential VCO architecture together with a unique charge pump design ensures that the PLL jitter is small. Differential VCO output can be converted into a single-ended output clock with the same frequency while maintaining its 50% duty cycle. This will ensure low power consumption for the PLL. Loop divider Dy can be selected with any integer numbers between 2 and 32.

FUNCTIONAL DIAGRAM

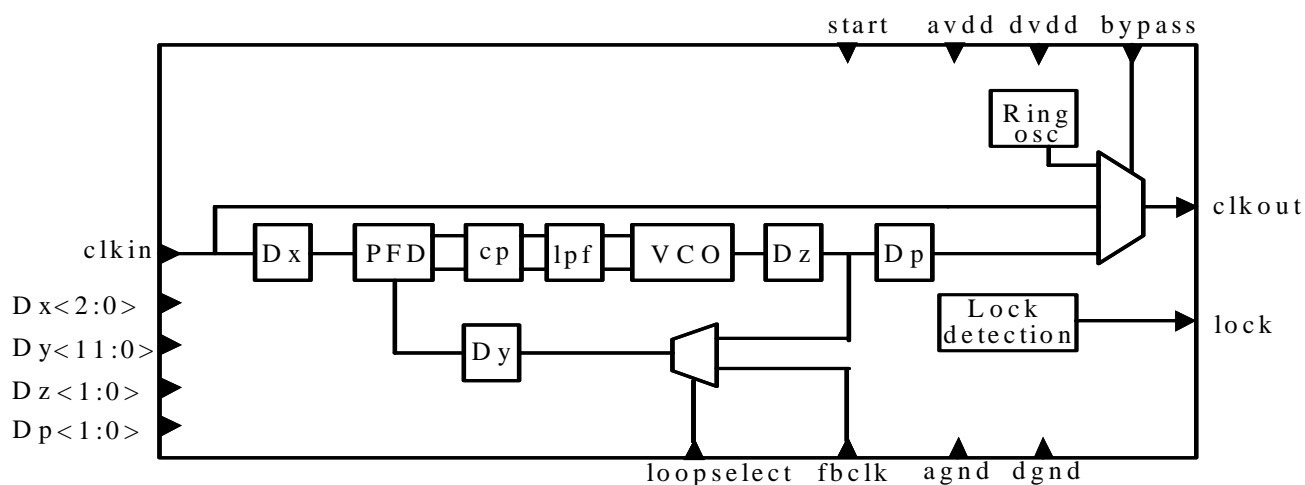

Dx can be 1, 2, 4, 8; Dz can be 1, 2, 4; Dp can be 1, 2, 4, 16; Dy can be set from 2 to 32

All questions concerning the document and/or other questions can be directed to Haokai Corporation as follows:

Add: 668 Beijing East Rd, Suite C810, Huangpu District, Shanghai P. R. China 200001

Tel: 86-21-51571430

Fax: 86-21-51571431

E-mail: products@haokai-micro.com

Copyright 2008 Haokai, Inc. All rights reserved. This documentation contains confidential and proprietary information that is the property of Haokai, Inc. Haokai home page can be found at <http://www.haokai-micro.com>