



FEATURES:

- PFD input frequency range: 500 KHz to 5 MHz
- Output frequency range: 20 MHz to 1.4 GHz
- Operating voltage range: 1.08 V to 1.32 V
- Operating junction temperature: -40° C to 125° C
- Area: 651 μm X 431 μm
- Pre-divider ratios: 1, 2, 4, 8, 16, 32, 64, 128
- Post-divider ratios: 1, 2, 4, 16
- Loop-divider Dy range: 60 to 3000
- Built-in loop filter
- Power-down mode
- Built-in lock detection
- Built-in ring oscillator
- By-pass mode

APPLICATIONS:

- Clock multiplication, clock generation; Various SOC and ASIC design, CPU etc

TECHNOLOGY:

- SMIC 0.13 μm mixed signal 1.2V/3.3 V CMOS

STATUS:

- Silicon proven on MPW

JITTERS:

- Peak-to-peak period jitter: 16 ps – 33ps
- Peak-to-peak period jitter: 2.13% - 3.62%
- RMS period jitter: 2ps – 7ps
- RMS period jitter: 0.25% - 0.74%

Brief description

The Haokai_PLL_130SMIC_01, a 0.13 μm phase locked loop (PLL), provides a clock generation and multiplication circuit that generates a stable, high-speed clock from a clock signal with very low input frequency range (500 KHz to 5 MHz). A differential VCO architecture together with a unique charge pump design ensures that the PLL jitter is small. Differential VCO output can be converted into a single-ended output clock with the same frequency while maintaining its 50% duty cycle. This will ensure low power consumption for the PLL. Loop divider Dy can be selected with any integer numbers between 60 and 3000.

Analog power/ground pins can either be directly connected to pins outside or to regulated power/ground on die.

The analog power/ground pins can be directly connected to the digital power pins too, with some jitter performance degradation.

Digital power pins can be directly connected to digital power net on chip, sharing the same power with other digital circuits.

FUNCTIONAL DIAGRAM

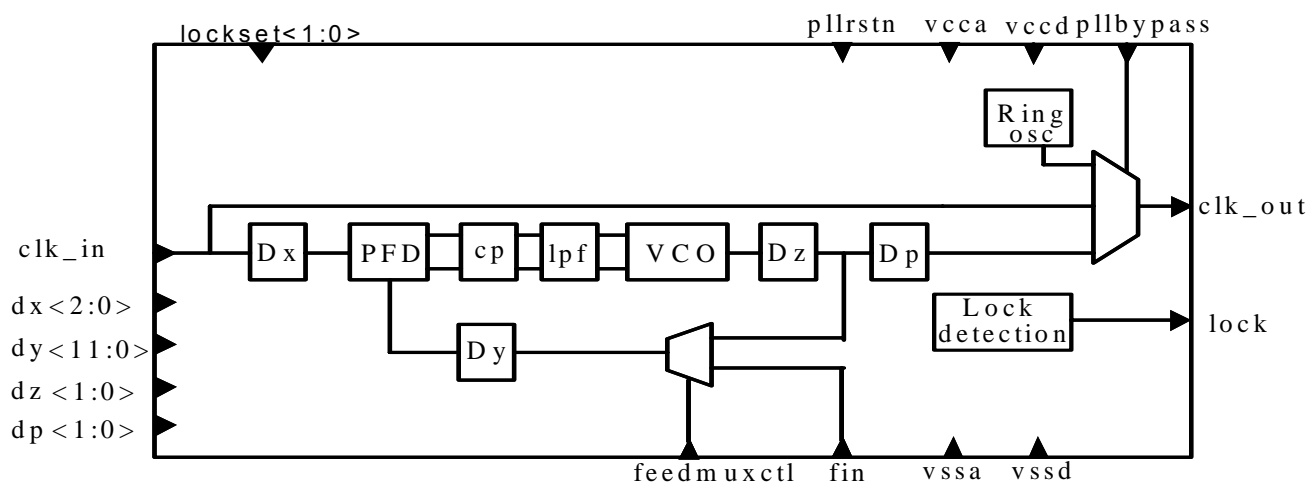

dx can be 1, 2, 4, 8, 16, 32, 64, 128; dz can be 1, 2, 4; dp can be 1, 2, 4, 16; dy can be set from 60 to 3000

The detailed explanation of each signal usage

Pin name	DIR	description
vcca	P	Dedicated analog power supply 1.2v
vccd	P	Dedicated digital power supply 1.2v
vssa	G	Dedicated analog ground
vssd	G	Dedicated digital ground
clk_in	I	Reference clock input from Crystal Oscillator or other clock sources
clk_out	O	Adjustable output clock
dx<2:0>	I	Input 3-bit divider control pins, dx<0> is LSB
pllrstn	I	Pllrstn=1 should be used in normal PLL operation, Pllrstn=0 power down control
dp<1:0>	I	Output 2-bit divider control pins, dp<0> is LSB
dy<11:0>	I	Feedback 12-bit integral divider control pins, dy<0> is LSB
pllbyypass	I	Bypass the PLL; Active high
feedmuxctl	I	Debug control pin ,Active high
lockset<1:0>	I	PLL lock detector control pins. 11 for normal mode
dz<1:0>	I	VCO to output 2-bit integral divider control pins
lock	O	Locked signal (high for locked)
fin	I	Input frequency for the custom to break the loop

The equation of the output frequency :

$$\text{clk_out} = \frac{\text{clk_in} \times \text{dy}}{\text{dx} \times \text{dp}}$$

$$\text{VCO} = \text{clk_out} \times \text{dz}$$

All questions concerning the document and/or other questions can be directed to Haokai Corporation as follows:

Add: 668 Beijing East Rd, Suite C810, Huangpu District, Shanghai P. R. China 200001

Tel: 86-21-51571430

Fax: 86-21-51571431

E-mail: products@haokai-micro.com

Copyright 2008 Haokai, Inc. All rights reserved. This documentation contains confidential and proprietary information that is the property of Haokai, Inc. Haokai home page can be found at <http://www.haokai-micro.com>