



**FEATURES:**

- PFD input frequency range: 30 MHz to 150 MHz
- Output frequency range: 20 MHz to 1.6 GHz
- Operating voltage range: 0.9 V to 1.1 V
- Operating junction temperature: -40° C to 125° C
- Area: 289 μm X 255 μm
- Pre-divider ratios: 1, 2, 4, 8, 16, 32, 64, 128
- Post-divider ratios: 1, 2, 4, 16
- Loop-divider Dy range: 2 to 60
- Built-in loop filter
- Power-down mode
- Built-in lock detection
- Built-in ring oscillator
- By-pass mode

**APPLICATIONS:**

- Clock multiplication, clock generation; Various SOC and ASIC design, CPU etc

**TECHNOLOGY:**

- SMIC 90 nm generic 1.0V/3.3 V CMOS

**STATUS:**

- Silicon proven on MPW

**JITTERS:**

- Peak-to-peak period jitter: 18 ps – 37ps
- Peak-to-peak period jitter: 0.7% - 4.7%
- RMS period jitter: 2.6ps - 7ps
- RMS period jitter: 0.12% - 0.62%

**Brief description**

The Haokai\_PLL\_090SMIC\_03, a 90 nm phase locked loop (PLL), provides a clock generation and multiplication circuit that generates a stable, high-speed clock from a clock signal with very large input frequency range (30 MHz to 150 MHz). A differential VCO architecture together with a unique charge pump design ensures that the PLL jitter is small. Differential VCO output can be converted into a single-ended output clock with the same frequency while maintaining its 50% duty cycle. This will ensure low power consumption for the PLL. Loop divider Dy can be selected with any integer numbers between 2 and 60.

Analog power/ground pins can either be directly connected to pins outside or to regulated power/ground on die.

The analog power/ground pins can be directly connected to the digital power pins too, with some jitter performance degradation.

Digital power pins can be directly connected to digital power net on chip, sharing the same power with other digital circuits.

**FUNCTIONAL DIAGRAM**

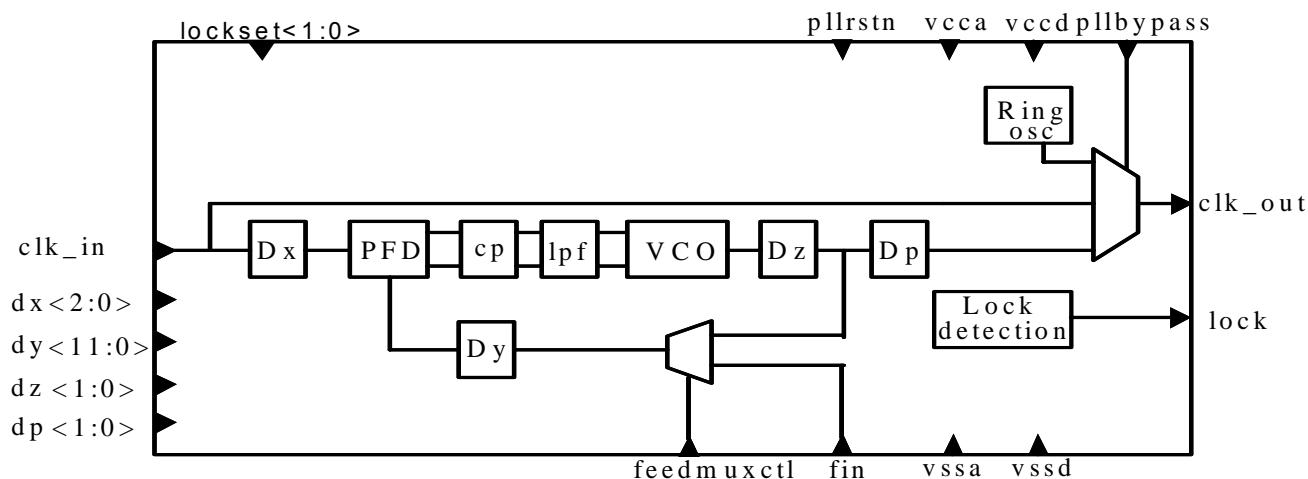

*dx can be 1, 2, 4, 8, 16, 32, 64, 128; dz can be 1, 2, 4; dp can be 1, 2, 4, 16; dy can be set from 2 to 60*

## The detailed explanation of each signal usage

Pin name	DIR	Description
vcca	P	Dedicated analog power supply 1v
vccd	P	Dedicated digital power supply 1v
vssa	G	Dedicated analog ground
vssd	G	Dedicated digital ground
clk_in	I	Reference clock input from Crystal Oscillator or other clock sources
clk_out	O	PLL output clock
dx<2:0>	I	Input 3-bit divider control pins, dx<0> is LSB
pllrstn	I	Pllrstn=1 should be used in normal PLL operation, Pllrstn=0 power down control
dp<1:0>	I	Output 2-bit divider control pins, dp<0> is LSB
dy<11:0>	I	Feedback 12-bit integral divider control pins, dy<0> is LSB
pllbyypass	I	Bypass the PLL; Active high
feedmuxctl	I	External feedback loop selection; Active high
lockset<1:0>	I	PLL lock detector control pins. 11 for normal mode
dz<1:0>	I	VCO to output 2-bit integral divider control pins
lock	o	Locked signal (high for locked)
fin	I	Input frequency for the custom to break the loop

The equation of the output frequency :

$$clk\_out = \frac{clk\_in \times dy}{dx \times dp}$$

$$VCO = clk\_out \times dz$$

All questions concerning the document and/or other questions can be directed to Haokai Corporation as follows:

**Add:** 668 Beijing East Rd, Suite C810, Huangpu District, Shanghai P. R. China 200001

**Tel:** 86-21-51571430

**Fax:** 86-21-51571431

**E-mail:** products@haokai-micro.com

Copyright 2008 Haokai, Inc. All rights reserved. This documentation contains confidential and proprietary information that is the property of Haokai, Inc. Haokai home page can be found at <http://www.haokai-micro.com>

Version 1.0 / May 2008